

Autodesk® based Shipbuilding & Offshore Solutions

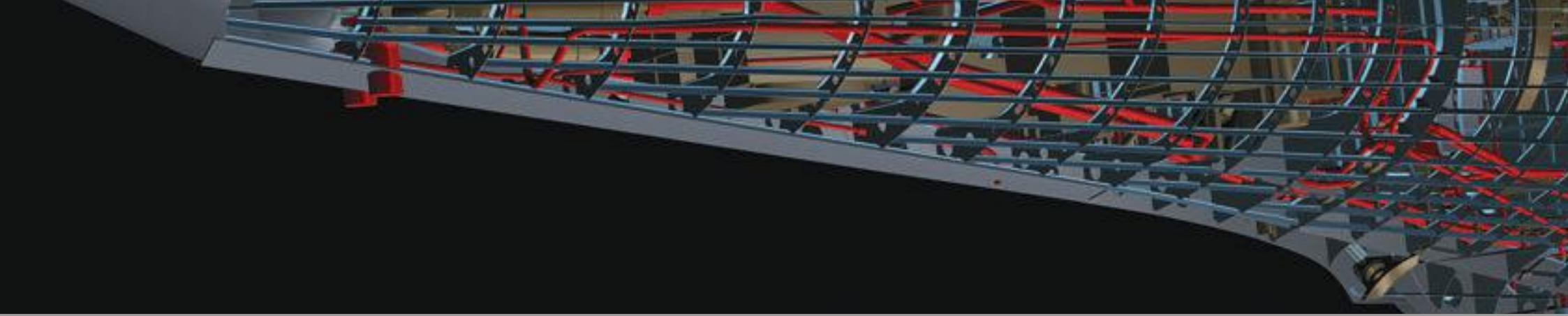

» ShipConstructor Products



» **ShipConstructor Overview**

ShipConstructor Key Differentiators **3,4**
ShipConstructor Key Benefits **5,6**

» **Hull/Structure Products**

Hull **7**
Structure **8**
MarineDrafting **9**
WeldManagement **10**
ManualNest and AutomaticNest **11**
ProfileNest **12**
NC-Pyros **13**

» **Outfitting Products**

Pipe **14**
PipeLink & P&ID DesignValidation **15**
HVAC **16**
Electrical **17**
Equipment **18**
Penetrations..... **19**
PipeSupports **20**

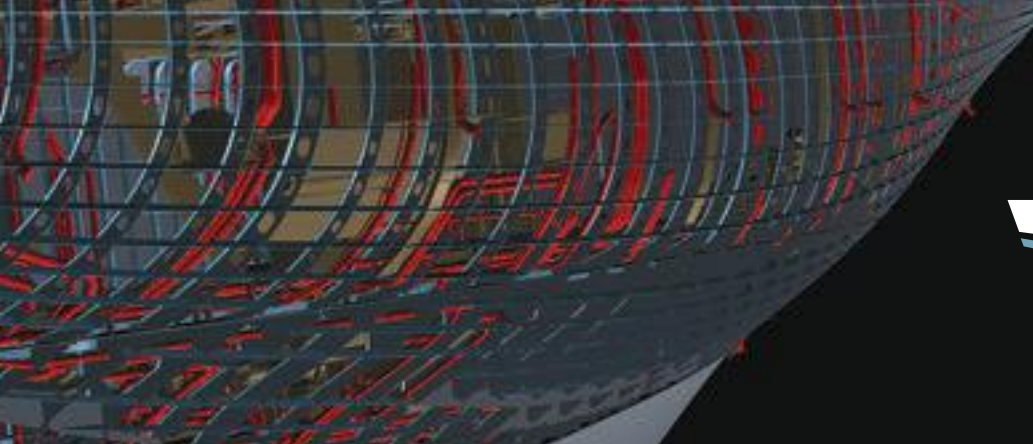

» **General Products**

ProductHierarchy 21
Report 22

» **WorkShare Products**

WorkShare Project 23
WorkShare Desgin 24

» **About SSI**

Company Description 25
Our Vision 25,26



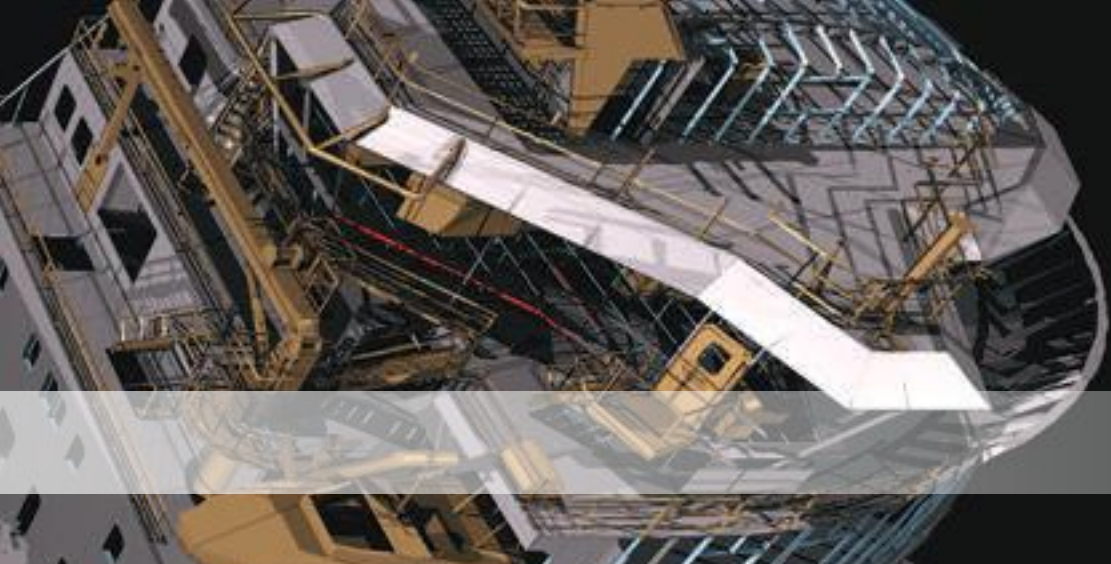

ShipConstructor Key Differentiators

Overview

ShipConstructor is a suite of AutoCAD based software products designed for engineering and construction in the shipbuilding industry. ShipConstructor's AutoCAD foundation provides a user environment that is a globally recognized CAD/CAM standard. This results in an existing labor pool of expertise, a common DWG format for sharing information with other applications, and a portfolio of complementary Autodesk products.

ShipConstructor's use of COTS technologies such as AutoCAD and Microsoft SQL Server allows it to be integrated with other business processes and applications. This enables it to address the requirements of all clients and projects. The Associative DWG capability of ShipConstructor's Marine Information Model provides true Concurrent Engineering for the first time in shipbuilding CAD/CAM; all engineering disciplines can work within a single integrated environment with associativity that extends to the production drawing level. These differentiators are combined in an industry specific product that incorporates shipbuilding standards, concepts and terminology.

» AutoCAD Foundation

AutoCAD provides the underlying CAD engine and drafting tools for ShipConstructor products. AutoCAD is one of the most widely used CAD applications available today and provides robust general purpose CAD tools with industry leading drafting capabilities. AutoCAD is a generic tool intended for broad applicability but with ShipConstructor, a specialized toolset is available, designed to meet the specific challenges of the shipbuilding industry. AutoCAD skills are common amongst engineers, designers and draftsmen.



» Industry Specific

ShipConstructor is superior to generic CAD solutions, or those developed for other industries, because it is designed to address the specific needs of the shipbuilding industry. Unlike these other solutions, ShipConstructor has been purpose-built on a foundation of shipbuilding expertise, concepts and terminology. This makes the software a natural fit for both the overall organization as well as the individual designers.

CONSTRUCTOR®



» Autodesk Platform

A ShipConstructor product model can seamlessly be utilized by other Autodesk applications. With the breadth and depth of the Autodesk portfolio, a comprehensive Autodesk based solution utilizing ShipConstructor can be implemented for a wide variety of complex enterprise-level business challenges.

This is because ShipConstructor products have an underlying AutoCAD engine and the core technology is consistent with the entire Autodesk Platform. ShipConstructor is as tightly integrated with the Autodesk portfolio as other Autodesk products. Consequently, Autodesk products (Autodesk Inventor, Autodesk Navisworks, Autodesk Vault, etc.) treat ShipConstructor as if it is a native AutoCAD vertical, allowing seamless integration.

» Associative DWG

Associative DWG allows AutoCAD based DWG production drawings, generated from the product model, to remain attached to the Marine Information Model and updated automatically as changes occur. These associative drawings can be modified using native AutoCAD tools as well as industry specific tools offered within ShipConstructor. The linkage to DWGs is critical because even if an organization uses a competing shipbuilding CAD/CAM software suite, it typically still uses AutoCAD to create drawings. This is due to the fact that AutoCAD is recognized as having the best drafting capabilities and is the standard for deliverables. ShipConstructor is the only solution that allows DWG based drawings to remain connected to the original engineering tools while being modified and published in the format chosen by much of the industry.

» Marine Information Modeling

SSI has pioneered an approach called Marine Information Modeling or MIM which enables true concurrent engineering and promotes interoperability with other business processes and applications. At the core of MIM is a complete virtual model of the entire vessel including each of the various disciplines, from hull production design and structural detailing, to outfitting and assembly sequencing. All work within a single integrated environment, sharing a consistent interface, and are connected via a project database that stores the intelligence, relationships, attribute information and 3D model, plus the rules and standards used in the product model's composition. The information within the database is associative at every level, beginning with the industry specific standards used to create the model and extending all the way to the automatically generated AutoCAD based production documentation used in the shipyard. This depth of associativity offered by MIM makes ShipConstructor the only solution that allows an engineering department to implement True Concurrent Engineering.

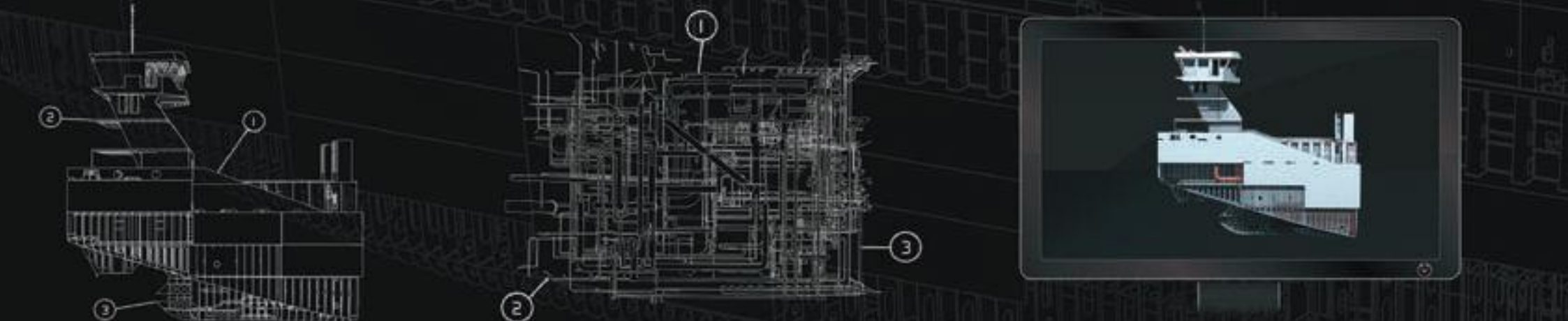

ShipConstructor **Key Benefits**

» **True Concurrent Engineering**

ShipConstructor is the only solution that allows true Concurrent Engineering. For the first time and only with ShipConstructor, drawings generated in the AutoCAD DWG format, the industry standard, can be automatically updated as the project evolves without losing any manual detailing or other work performed directly in the drawings. With the development of MIM and the tight integration between ShipConstructor and AutoCAD, SSI was able to develop an essential and innovative ShipConstructor technology called Associative DWG. Associative DWG allows Concurrent Engineering to also extend to the AutoCAD DWG based production drawings such as nests, arrangements, spools, and assembly drawings.

» **Scalability**

Scalability applies to multiple realities of our clients and is critical to the management of risk around growth and changes to technology. The SSI solution is significantly more scalable than any other competing shipbuilding software on the market, making it the only product suitable for clients with differing budget sizes, differing workforce skills and abilities, differing infrastructure environments, and differing project types and sizes.

» **Configurability and Flexibility**

All organizations in the shipbuilding and offshore industries worldwide share many of the same challenges and requirements. However, no two organizations are exactly the same and unique competitive advantages are often derived from these small differences. ShipConstructor does not constrain you to a specific workflow or to a narrow choice of complimentary 3rd party products. It can be implemented in a different way within the same organization as requirements change, or according to the requirements of different organizations.



» **Interoperability**

The most common language in use today for the communication of CAD data is DWG. Since DWG is the native format for ShipConstructor model data and production drawings, ShipConstructor is uniquely positioned to allow the highest degree of interaction with other internal departments and also the supply chain. In the marine industry specifically, DWG is a standard for communication with suppliers, subcontractors, classification societies, and project owners. By facilitating this communication, ShipConstructor lowers the costs associated with interacting with other organizations and reduces the risk of errors inherent in currently required conversion processes.

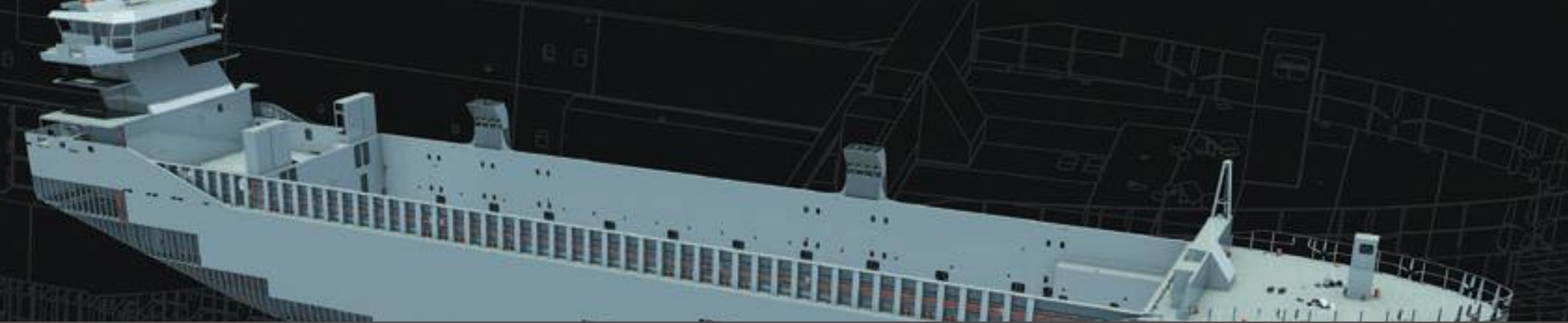

» Speed to Proficiency

Clients can more easily find and train staff due to ShipConstructor's combination of a familiar AutoCAD platform, the use of shipbuilding specific terminology and concepts, and SSI's commitment to ensuring that the software maintains an innovative and intuitive design.

SSI is dedicated to ensuring that the latest software technology innovations are harnessed towards increased usability at the same time as efficiency enhancing features are added. The use of terminology already familiar in the industry rather than abstract geometric concepts further enhances the intuitive nature of the software making it natural to learn.

Perhaps the largest contributor to ShipConstructor's intuitiveness is its AutoCAD foundation. With over 10 million users of Autodesk products worldwide, the majority of engineers, designers and new graduates have AutoCAD skills and therefore have already completed a portion of the training required for ShipConstructor. If employee turnover is a challenge, this directly lowers the cost of employee training, allowing a skilled workforce to be created in shorter time with lower overhead.

» Security and Control

Actions and workflows can be controlled by either individual or departmental permissions. These permissions allow organizations to align what can be done in the software with the skill level of specific individuals and the requirements of business processes. This provides an additional level of security and reduces rework due to unauthorized or unintentional changes. The combination of flexible controls and user level revision tracking on changes available in the product allows for a high degree of accountability.

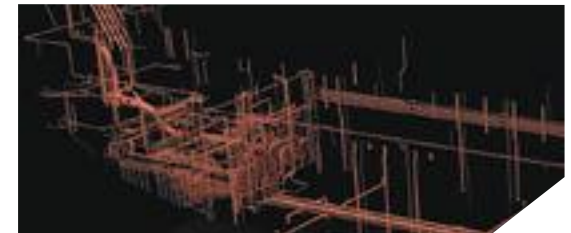

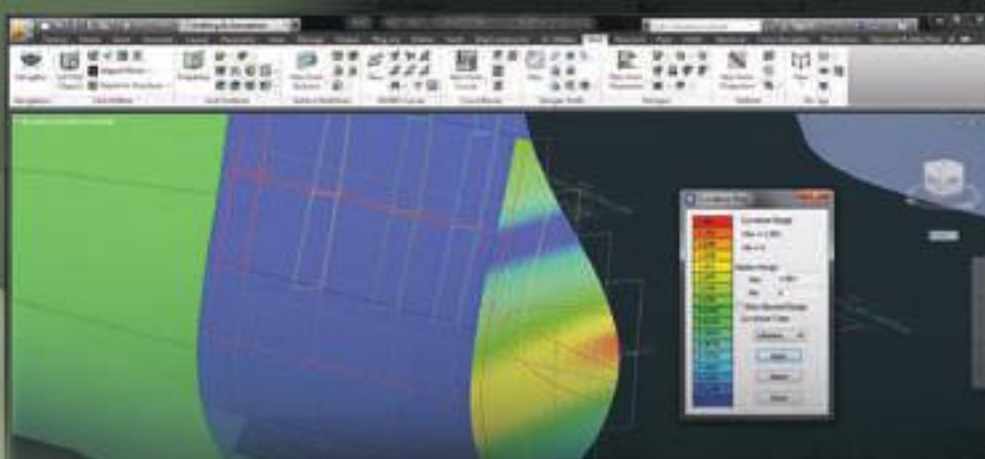

Hull/Structure Products: **Hull**

Hull Overview

Hull combines purpose-built shipbuilding specific surfacing technology and the simplicity of working inside of AutoCAD. This brings together the best of two worlds. It allows for easy and intuitive creation and manipulation of complex surface models while also allowing the freedom to use standard AutoCAD drafting techniques.

Hull provides powerful features such as surface-surface intersection, surface trimming, plate expansion, structural section definition, shell expansion, shell stringer definition, offset book printing, and pin jig drawing generation. The data designed in the external hull production model flows freely into the Structure product.

» Retain Flexibility

No limits are placed on the choice of initial design tools since ShipConstructor provides the ability to import data in various industry standard formats including IGES and DXF, as well as natively from AutoCAD, Maxsurf or Rhino surfaces. Data created in Hull can seamlessly be utilized in Structure.

» Ensure Production Accuracy

ShipConstructor has tools that allow existing design surfaces to be analyzed, modified and faired in a production context. These tools ensure that only high quality design information makes its way to the shop floor.

» Hull Key Features

- Capture design data from initial design
- Section, mark, and trim existing surfaces
- Create new design surfaces
- Fair surfaces to production detail
- Analyze curvature
- Create and manipulate shell stringers
- Expand production quality plates
- Create forming templates, analyze strain
- Send pieces to Structure for production
- Create pin jig drawings



Structure Overview

Structure offers rapid 3D production detailing of internal hull structure. It combines aspects of both associative and parametric 3D modeling but is tailored specifically to the design of ships and offshore structures. Accurate and intelligent 3D project models can be created very quickly utilizing a cross section of shipbuilding specific capability and native AutoCAD tools.

» Manageable Change

The intuitive, associative modeling tools found in the ShipConstructor Structure product allow changes to be made to existing designs in a predictable and manageable way. Since a change in a portion of the product model will cause modifications in other portions, ShipConstructor outlines what those modifications will be. This provides a true understanding of the impact of any change.



Hull/Structure Products: **Structure**

» **Intelligent Models with Less Effort**

Associations in the 3D project model are automatically created as the user employs standard AutoCAD commands during the design process. This provides the benefits of an associative modeling environment without the extensive training and experience that is often required.

» **Standards-Based Design**

The 3D project model is built using a range of configurable shipbuilding standards including flanges, profile cutouts, standard brackets, stiffener endcuts, marking styles, corner treatments and more. The required standards are either selected manually by the user or automatically selected according to predefined associative rules for each project. As these standards are changed in the library over time, the project model automatically reflects their current state.

» **World Class Drafting**

ShipConstructor provides an array of marine specific tools that are required in the detailing of production drawings. These tools include: configurable BOMs; automatic labeling of piece parts, spools and assemblies; spool dimensioning; weld symbols; quality control and more. These capabilities build on and work together with the 2D drafting capabilities provided by AutoCAD, the world leader in this area.

» **Associative Production Design**

Production information including expanded flange information, stiffener marklines, bevel information and more is automatically created from shipyard standards contained in the project library as the 3D model is built. The production information remains associatively linked to the related elements in the 3D project model as changes occur.

» **Design Reuse**

A combination of Standard Assemblies and the capabilities of WorkShare allow existing work to be leveraged. This results in a significant reduction in engineering hours. These tools allow the reuse of individual portions of the project model, entire blocks and their corresponding production drawings, or entire projects.

» **Structure Key Features**

- Define internal plate structure
- Define internal profiles and extrusions
- Automatically generate part names
- Automatically add stiffener cutouts
- Automatically add required bevel information
- Define planking sections
- Automatically create associative marking for piece marks, part orientation, stiffeners, bevels, faceplates and more
- Apply extra material to part boundaries
- Create 2D Workshop and Class Approval drawings
- Create 3D Assembly drawings from all disciplines
- Create 2D profile plots and sketches

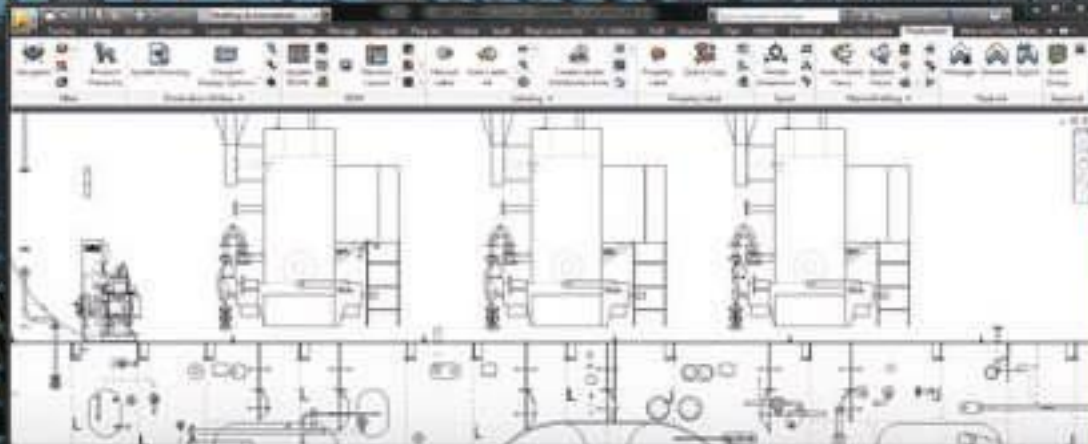

Hull/Structure Products: **MarineDrafting**

MarineDrafting Overview

In a world of 3D design and manufacturing, many activities still need to be supported with 2D drawings during design and throughout the shipyard. Using shipyard standards, MarineDrafting allows the creation of 2D approval and workshop drawings directly from the 3D model. These drawings are created in AutoCAD DWG format and remain associatively linked to the 3D model as changes happen.

» Reduce Work

The shorter and shorter project schedules associated with today's demanding shipbuilding programs are causing more overlap between each phase of design and engineering. This overlap means that the 3D design continues to progress after approval or workshop drawings have been created. The 2D drawings generated with MarineDrafting remain linked to the model and can be updated throughout the life of a project. This can significantly reduce the amount of rework required when changes occur.

» Reduce Effort

The 2D drawings created using MarineDrafting are automatically generated from the 3D product model. The drawings are created from a combination of configurable shipyard standards, AutoCAD styles and templates, the 3D geometry within the model, and the relationships and attribute data from parts in the model.

» Leverage Existing Skills

The drawings created using MarineDrafting remain associatively linked to the model and contain a significant amount of industry specific information. However, these drawings can be modified and further detailed by a user using only AutoCAD capabilities, skills and knowledge. A significant number of the class approval drawings generated today are created and detailed by drafters using AutoCAD. Marine Drafting provides a significant number of benefits as part of ShipConstructor without requiring many new skills to be learned.

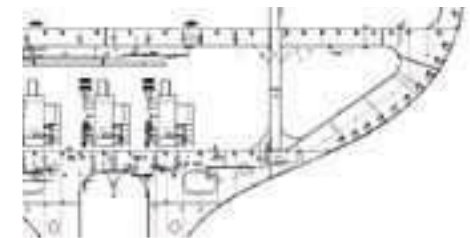

» MarineDrafting Key Features

- Define shipyard, project, and class society specific standards
- Automatically generate 2D class approval and workshop drawings
- Automatically update drawings without losing changes
- Modify existing drawings using AutoCAD



Hull/Structure Products: **WeldManagement**

WeldManagement Overview

Weld is a production and management system for structural welds in ShipConstructor. This product provides the ability to fully customize weld symbols and standards. It also provides the ability to develop a weld schedule for each particular project. Once welds have been defined in the project (including automatic identification and weld path generation) configurable weld reports can be generated for any assembly, or for the entire project.

» Plan with Confidence

Welds are derived via a combination of the build sequence in the ProductHierarchy and the 3D geometry in the product model. This allows accurate reporting of total weld length for any assembly and can be used to plan and sequence shipyard activities.

» Effectively Manage Change

As the 3D model, build strategy and other areas of the project change over the duration of the project, welds which have been already generated will be flagged as needing attention and can be modified or re-generated as necessary. These changes will be automatically reflected in production output and reports.

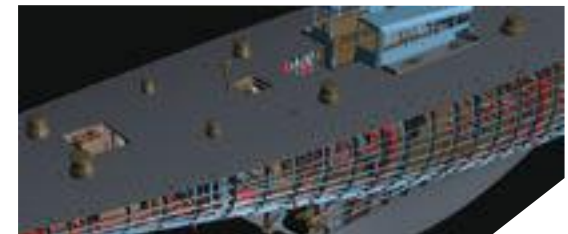

» WeldManagement Key Features

- Define project specific weld standards and symbols
- Define a project specific weld schedule
- Automatically find and generate weld paths
- Find and track undefined welds
- Assign weld standards to identified welds
- Identify required weld changes as 3D model changes
- Create customizable reports for welding data
- Automatically insert weld information in assembly drawings



Hull/Structure Products: **ManualNest** and **AutomaticNest**

Manual Nest and Automatic Nest Overview

Nesting is tightly integrated into the central project database, providing features to nest by assembly, stock, material, surface treatment, port/starboard, like/mirror cut, and full remnant control. ManualNest and AutomaticNest provide standard tools to align parts and insert bridges.

» **Optimize Material Usage**

Settings can be adjusted for material and thickness, for required part gaps, and also for nest edge gaps. These settings, when combined with a configurable automatic nesting engine, provide a high degree of nest and plate utilization. The ability to track and nest on the remnants of any used plate further increases stock utilization and keeps material costs down.

» **Integrated Design**

As changes happen to the 3D project model (including structural changes affecting nested parts, or outfitting changes causing new or modified penetrations in nested parts), individual nests are flagged as requiring attention and the affected parts can either be updated or re-nested as required. This allows nesting to begin earlier in parallel with outfitting, and respond to any late changes.

» **Production Feedback**

NC-Pyros can generate NC-code for a given nest, for virtually any cutting machine. During this stage, the fast travel, mark and cut times for the plate (including time required to pierce the specific material), can be synchronized back to the nest and included in nest reports. This information can be used to optimize the cutting sequence in production planning and estimate the time required for future projects.



» **Manual Nest and Automatic Nest Key Features**

- Automatically nest plate and flat profiles
- Track nested and un-nested parts
- Filter nesting by numerous options including build strategy
- Manually optimize existing nests
- Control stock inventory
- Create and utilize remnant stock
- Update nested parts as the product model changes
- Create customized nest reports
- Capture nesting times from NC software

Hull/Structure Products: **ProfileNest**

ProfileNest Overview

ProfileNest performs linear nesting of profiles onto available stock to optimize utilization and streamline production, including available and used stock control, heat number tracking, and full production reports.

» **Integrated Design**

As changes happen to the 3D project model, individual nests are flagged as requiring attention and the affected parts can either be updated or re-nested as required. This allows nesting to begin earlier and respond to any late changes.

» **Integrate Engineering and Production**

Nesting of parts is driven by assembly stages within the ProductHierarchy which can be selected based on the need by dates for specific work products. These capabilities allow nesting operations to be performed based on the requirements determined by production planning.



» **ProfileNest Key Features**

- Automatically nest all profiles
- Track nested and un-nested parts
- Filter nesting by numerous options including build strategy
- Control stock inventory
- Create and utilize remnant stock
- Update nested parts as the product model changes
- Create customized nest reports

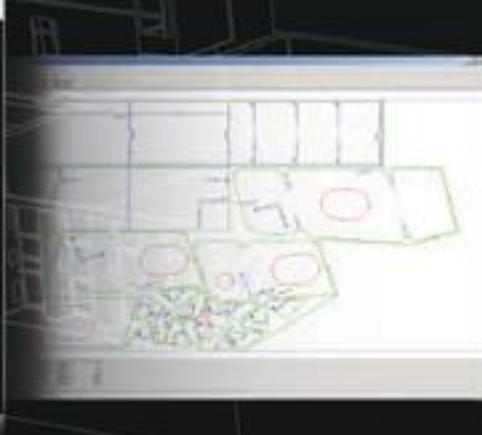
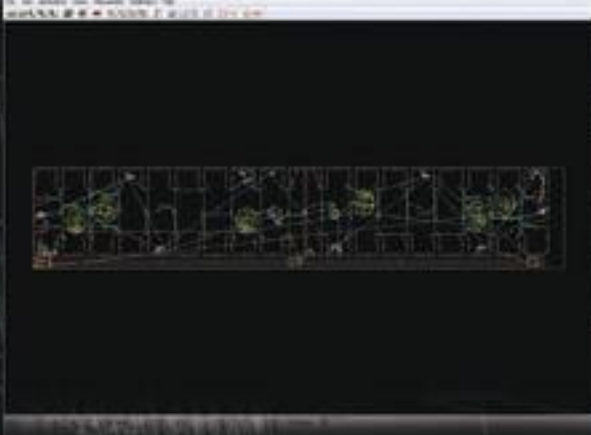

Hull/Structure Products: **NC-Pyros**

NC-Pyros Overview

NC-Pyros reliably creates NC-Code for any type of NC-cutting machine: oxy-fuel, plasma, laser, water-jet, or router. The integration with the product model automatically feeds back important information such as estimated cutting time, processing date, and operator name. This completes report data and simplifies any recalls. NC-Pyros-Bevel allows for adding variable angle cut and multi-torch weld preparation to NC-Pyros.

» Integrate with Engineering

Once NC-Pyros has determined an optimal cutting sequence for the parts within a specific Nest, estimates for cut, mark and fast travel times can be fed back into ShipConstructor. These estimates can be reflected in Nest drawings, and used in reports to estimate total time required to cut a specific nest, or all nests within a portion of the ProductHierarchy. Additionally, the cutting sequence can be back-plotted into ShipConstructor Nest and overlaid onto a Nest drawing. This allows the Nest operator to further optimize nesting based on the cutting sequence, analyze issues or add further bridges or other details to eliminate issues that could be encountered when the Nest is cut.

» Work with Your Infrastructure

NC-Pyros is shipped with controller files for virtually every NC machine actively used in the shipbuilding industry today. In the rare case a machine is encountered that requires minor modifications to an existing controller file, the required modification is included with a ShipConstructor Subscription. SSI also offers services to create controller files for previously unknown machines or unique capabilities for known machines that require a higher degree of customization. This allows clients to use ShipConstructor with their existing assets with little to no disruption.

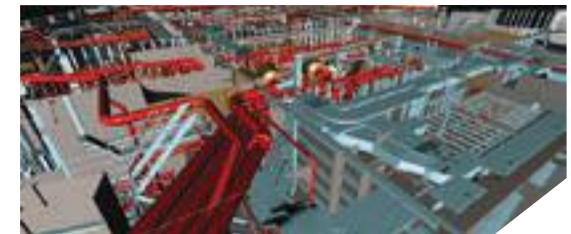

» NC-Pyros Key Features

- Import nests in DXF format (including non ShipConstructor Nest)
- Determine and simulate optimal cutting and marking path
- Generate NC code for virtually any machine
- Feed nesting times back to the product model



Outfitting Products: **Pipe**

Pipe Overview

Pipe is a complete production design package for pipe systems. Pipe modeling capability is spec-driven, based on a user-defined parametric catalog of pipe stocks and standards with logical connections between parts in the model. A powerful constraint based modeling system allows intuitive changes to existing piping systems. Pipe spools can be defined which are carried over into production for the creation of spool drawings and inclusion in the build strategy for pre-outfitting.

» Create Correct Designs with less Effort

Permission controlled, specification driven routing ensures the correct selection of standards for the current system as well as the correct selection of flanges, allowable bend radius, gaskets, accessories, connection gaps, and fittings. This ensures that the modeled systems conform both to the required specifications and to production requirements.

» Effective Change

An intelligent transformation engine allows existing systems to be modified in a controlled fashion, either by grabbing and stretching systems as required, or by using tools to find and replace existing elements or insert new fittings into existing pipe lines.

» Integrated Design

3D piping design is performed in the context of the overall 3D project model. Robust tools exist to route offset from existing structure or other systems, define penetrations within structure which anchor pipe in place once approved, and connect pipe to equipment and other systems in the model.

» Design Reuse

A combination of Standard Assemblies and the capabilities of WorkShare allow existing work to be leveraged towards a significant reduction in engineering hours. These tools allow the reuse of individual portions of the project model, entire blocks and their corresponding production drawings, or entire projects.



» Pipe Key Features

- Define systems/branches with default specs
- Route complex piping systems
- Easily route offset from systems or structure
- Dynamically modify existing systems
- Automatically apply spec-driven accessories
- Insert fittings into existing lines
- Find and replace in use items
- Automatically generate spool names from system, build strategy and other data
- Automatically generate spool drawings
- Automatically create 3D Pipe and Equipment arrangement drawings
- Value Added Modules

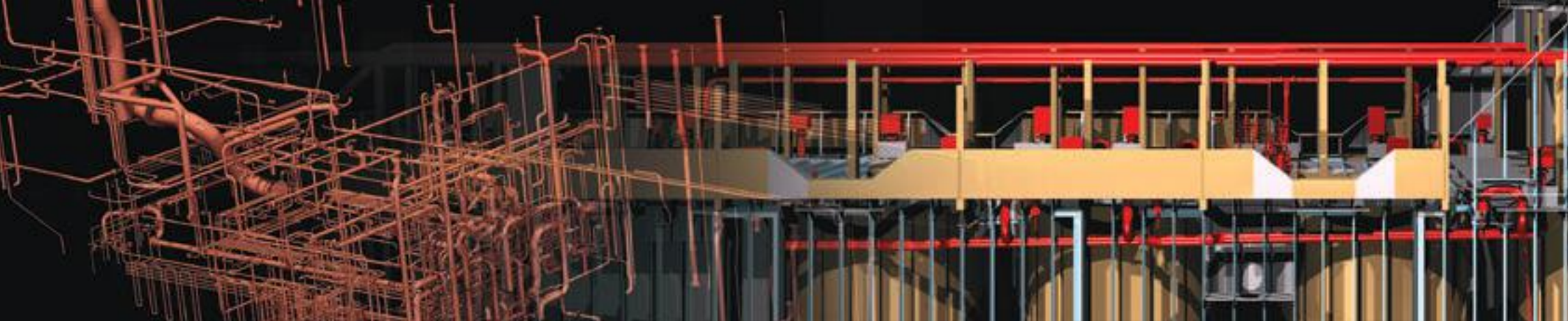

Outfitting Products: PipeLink and P&ID DesignValidation

PipeLink Overview

PipeLink allows the piping systems within a ShipConstructor project to be used within other business processes, and applications. This is accomplished through an export to the PCF format from within a ShipConstructor production drawing.

» Automate Business Process

In the piping world PCF is a standard format that can be read and written by a large number of applications. These applications include software for the analysis of pipe stress, generation of isometric drawings in formats required by certain segments of the industry, and control of automated pipe bending machines on the shop floor. PipeLink provides the ability to generate PCF files that can be used to automate these individual tasks using information contained within ShipConstructor.

P&ID DesignValidation Overview

P&ID DesignValidation allows for the checking and validation of the ShipConstructor 3D pipe model against 2D schematics generated in standalone P&ID software including AutoCAD P&ID. The validation is performed using neutral formats in order to allow clients more flexibility in the choice of P&ID software.

» Create Correct Designs with less Effort

A significant number of software applications exist that allow for the creation of 2D piping schematics. P&ID DesignValidation allows users to validate the 3D model in ShipConstructor against existing schematics to ensure that the schematics and model are consistent. This results in fewer errors making their way to downstream processes.

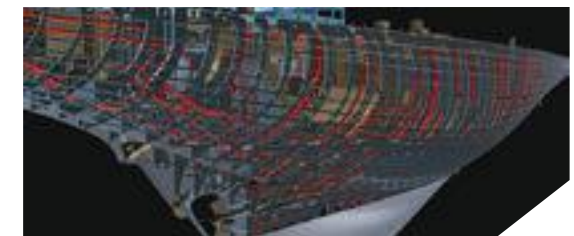

» PipeLink Key Features

- Generate PCF files from any production drawing
- Configure PCF output for the requirements of a particular task

» P&ID DesignValidation Key Features

- Compare Tag numbers and other relevant data between the 3D model and schematic
- Identify inconsistent information on items with the same Tag number in the 3D model and schematics
- Identify missing components in either the 2D schematic or 3D model
- Configure the underlying comparison engine to specific requirements



Outfitting Products: HVAC

HVAC Overview

HVAC (Heating Ventilation and Air Conditioning) integrates with all of the other ShipConstructor modules and encourages collaboration between departments. HVAC can be based on a parametric catalog of stocks or can be driven by on-the-fly item creation depending on the client's needs. The software employs the same constraint based modeling engine used in Pipe.

» Create Correct Designs with less Effort

Permission controlled, standards driven routing ensures the correct selection of standards for the current system as well as the correct selection of connections, gaskets, accessories, connection gaps, and transitions. This ensures that the modeled systems conform both to the required specifications and to production requirements.

» Effective Change

An intelligent transformation engine allows existing systems to be modified in a controlled fashion, either by grabbing and stretching systems as required, or by using tools to find and replace existing elements or insert new fittings into existing ducts.

» Integrated Design

3D HVAC design is performed in the context of the overall 3D project model. Robust tools exist to route offset from existing structure or other systems. Ducts will be anchored in place once penetrations through existing structure have been approved. Additionally, HVAC has tools to connect ducts to equipment and other systems in the model.

» Design Reuse

A combination of Standard Assemblies and the capabilities of WorkShare allow existing work to be leveraged towards a significant reduction in engineering hours. These tools allow the reuse of individual portions of the project model, entire blocks and their corresponding production drawings, or entire projects.



» HVAC Features

- Define systems/branches with default standards
- Route complex systems
- Easily route offset from systems or structure
- Dynamically modify existing systems
- Automatically apply connection accessories
- Find and replace in use items
- Automatically generate spool names from system, build strategy and other data
- Automatically generate spool drawings
- Automatically create 3D HVAC and Equipment arrangement drawings



Outfitting Products: **Electrical**

Electrical Overview

Electrical is a 3D modeling and production system for wireways, cable trays, supports, cables and transits. It features an associative 3D model connecting allocated space to individual wireways, cable trays, supports and subsequent cables. Associative production documentation can be generated from the model including cable pull schedules and reports. The cables within the model are automatically routed within the ShipConstructor environment according to EMC ratings, minimum bend radius and more.

» Detect Issues Early

Electrical is often one of the last disciplines to be considered and one of the most difficult to allocate space for. Space can be allocated early in the design process using Space Allocations which can be used in all interference checking against structure and other systems. These space allocations will then be used as the foundation for electrical wireways and cable supports ensuring that late issues should not arise.

» Effective Change

Cables, wireways, cable supports and space allocations within the 3D model are associatively connected. As changes are made to space allocations, wireways, and cable lengths are automatically updated. This level of associativity in the 3D Electrical model reduces the amount of manual work, and resulting errors, that must be performed when change is required.

» Accurate Cable Lengths

Cables are created and automatically routed in 3D resulting in more accurate cable lengths and installation information in cable pull sheets and reports. This leads to lower material handling costs and less wasted cable as it is pulled through the ship.



» Electrical Key Features

- Allocate space early in the process
- Define a master equipment list
- Model electrical wireways
- Model standard cable supports and trays
- Define EMC zones
- Automatically route cables
- Automatically route cables
- Parametrically update wireways and cables as systems change
- Create cable pull schedules and electrical arrangements

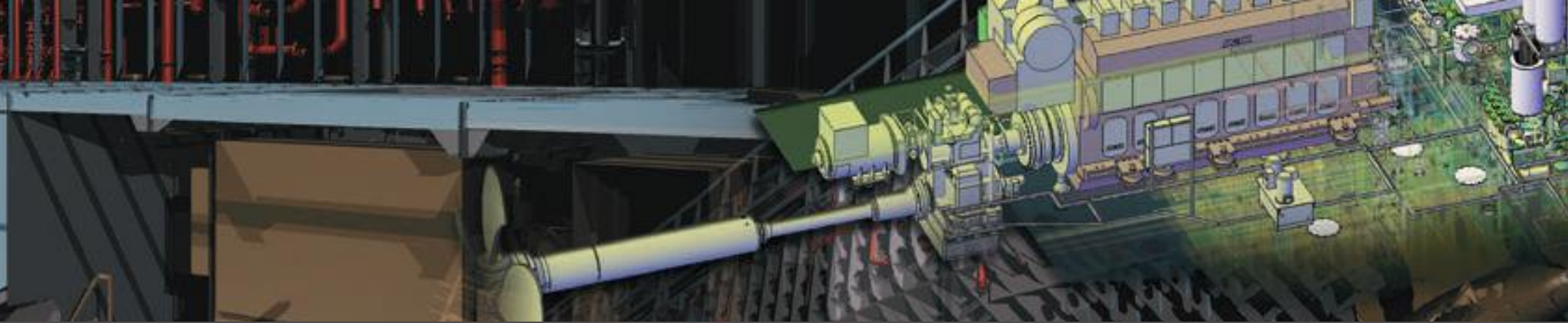

Outfitting Products: **Equipment**

Equipment Overview

Equipment provides the ability to insert any type of equipment item into a ShipConstructor model. The equipment items can be modeled in almost any modeling software, including directly in AutoCAD, and then incorporated into the ShipConstructor database. At this point, HVAC and Pipe connections are added as well as production specific attribute information. Once standards have been defined they are ready to be placed in the model.

» Communicate Effectively with the Supply Chain

Information regarding the equipment to be used in a ship comes from a diverse array of sources: vendor furnished information (VFI) from the supplier or original manufacturer, previous projects, online repositories, and in-house modeling efforts within engineering. The number of CAD formats this introduces is staggering. The DWG format and AutoCAD's native capabilities in this area allow any of these formats to be used without significant manual effort.

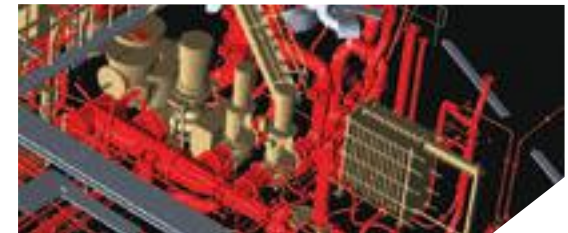

» Equipment Key Features

- Define 3D models of all project equipment
- Import native geometry in virtually any format
- Define logical Pipe, HVAC, and Electrical connections
- Create User Defined Attributes for custom information
- Import and export Equipment for reuse in other projects
- Specify multiple insertion points for each piece
- Insert Equipment into 3D model
- Build Standard Assemblies including related equipment and foundations

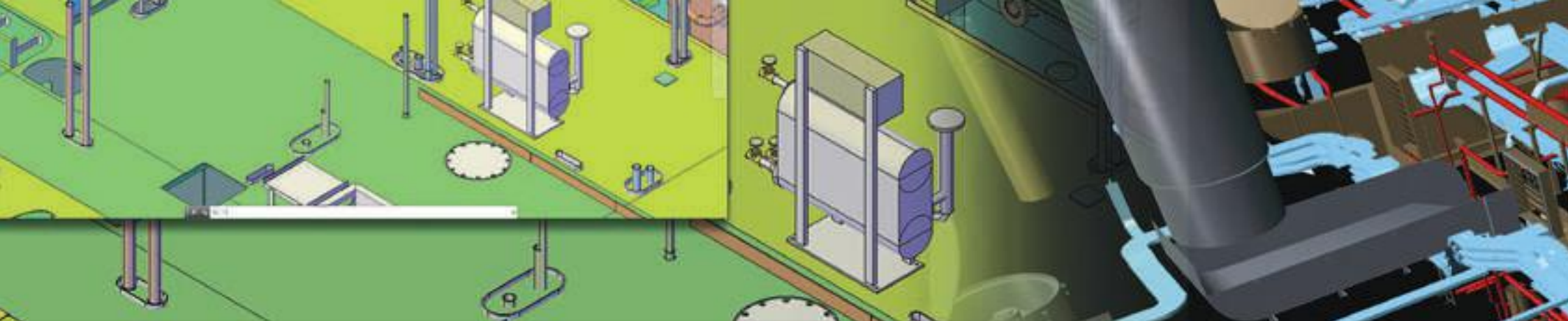

Outfitting Products: **Penetrations**

Penetrations Overview

Penetrations allows the creation of intelligent penetrations through structural members. The parametric spec-based penetration standards support features such as multi-pipe (and HVAC) penetrations and penetration accessory items.

» Controlled Penetration Workflow

A built in permission controlled approval process allows each penetration to be managed as it flows through to production. Several states from Pending to Approved exist which control whether a penetration, or its related structure, pipe or HVAC parts can be modified, and whether the penetration itself is ready to be included in production output.

» Integrated Design

Penetration doublers, sleeves and collars use the standards and materials defined by the structural department, and are treated as structure parts for plate and profile nesting, profile plots, and other production drawings.



» Penetrations Key Features

- Define specification driven penetration standards
- Control approval process via action-specific permissions
- Constrain penetration standards per specification
- Nest and produce penetration components
- Revise existing penetrations
- Automatically include penetrations in production drawings
- Generate customizable reports



Outfitting Products: PipeSupports

PipeSupports Overview

PipeSupports offers parametric design of supports based on shipyard standards. Supports are associated with pipe and pipe hangers as well as foundation structure to constrain and automatically adapt to design changes as the project progresses. The ability to generate support fabrication drawings linked to the model provides a smooth transition from engineering to production.

» Optimize Production

Supports for piping systems are based upon a user defined library of parametric templates. This allows the creation of supports for any situation, while ensuring that production can optimize processes around materials and manufacturing of supports as each support that is to be produced will be variations on a theme.

» Integrated Design

Plates, profiles, endcuts, cutouts and other standards used to compose pipe supports are selected from the structural standards defined by the detailed design team for structural design. The parts that are generated for each support are treated as native parts within Structure and other products, allowing them to be nested and included in production output as required.

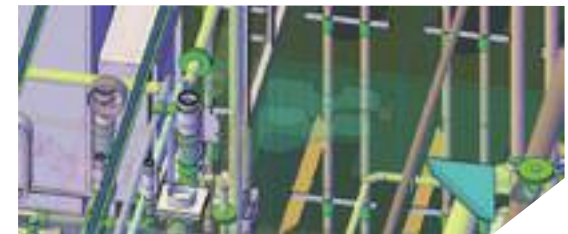

» PipeSupports Key Features

- Define standard support templates
- Define a variety of pipe hangers
- Insert pipe support instances based on system configuration
- Associate supports with piping systems
- Nest and produce support elements (profiles, doublers...)
- Automatically create template based construction drawings

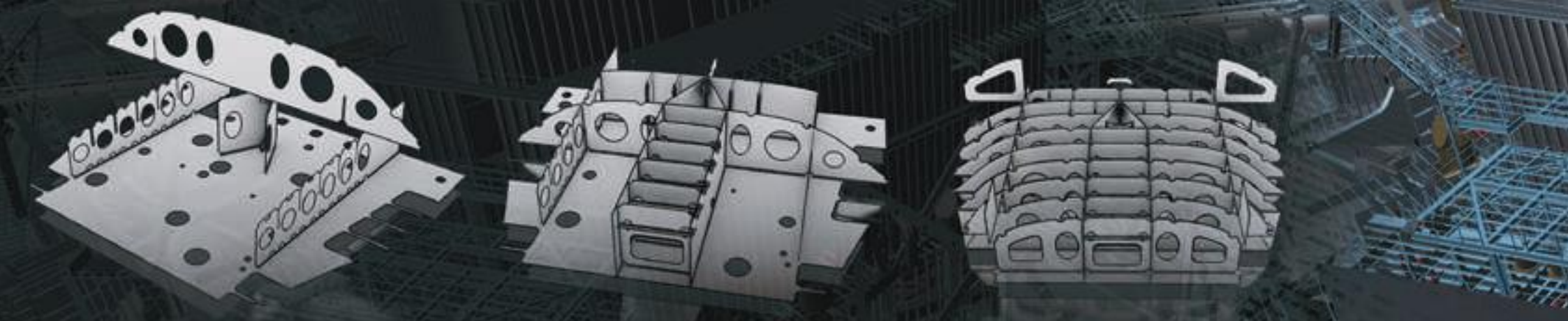

General Products: **ProductHierarchy**

Product Hierarchy Overview

ProductHierarchy is the hub within a project for production preparation. The build strategy is the primary product hierarchy which defines the assembly sequence for the project. Every part produced in each of the various modules has a place in the build strategy. Planning and scheduling departments define the build strategy to optimize the logical sequence of assembly based on production capabilities together with need-by and procurement dates. All ShipConstructor production output functions are driven by the build strategy, allowing for near-automatic generation of production drawings.

» **Effectively Integrate Engineering and Production**

The product hierarchy allows each of the disciplines to come together at various stages within the assembly sequence for the project. 3D assembly drawings, arrangement drawings, and spool drawings are then generated automatically from the defined sequence, facilitating a high degree of modular construction. Additionally, production oriented activities such as plate and profile nesting can be driven by the defined assembly sequence.

» **Centrally Manage Project Data**

Production drawing generation, report generation, part naming and assembly visualization are all driven by the product hierarchy. Additionally, user defined attributes can be added to the items in the product hierarchy and used to drive or integrate with other processes. The product hierarchy becomes the central location from which much of the ShipConstructor project data can be located and managed.

» **Effectively Manage Change**

Parts, spools, drawings and other artifacts can be automatically named via an intelligent rule based name generation engine that considers individual part attributes, location, type, drawing, and the location of the part or item in any of the defined product hierarchies. As the assembly sequence is modified, or parts are moved from one assembly to the other, the naming engine automatically reacts to the change without any input from the user. This ensures that part names are correct with little to no effort.



» **ProductHierarchy Key Features**

- Create user defined build strategies
- Include work products from all disciplines
- Automatically generate and update part names based on location
- Filter and generate production output by product hierarchy location
- Visualize portions of the product hierarchy in 3D
- Interact with the product hierarchy in 3D or via the logical user interface
- Drag and drop modification of product hierarchies



General Products: Report

Report Overview

ShipConstructor provides a flexible, powerful tool for generating non-graphical production information. Report allows for the definition of complex production detail reports that can be generated from the central project database on demand. With advanced features such as grouping, sorting, summary fields and full control over the visual aspects of the report, this tool provides the means to extract the information required for the entire team. Any report can be exported to formats such as Microsoft Excel for further calculation and analysis.

» Harness Existing Data

Report allows for the creation of reports using virtually every piece of information stored within the product model database. This includes both ShipConstructor standard information as well as all user defined attributes created by an organization. Each report can be exported to a variety of standard formats, allowing the information contained within to be harnessed for a wide variety of tasks.

» Customize to your Needs

Every report, whether it is included by default with the software or created by a client, can be customized using a wide range of tools. These tools range from the ability to change the available data fields and look and feel of the report, to powerful tools for grouping and summarizing complex information within the report.

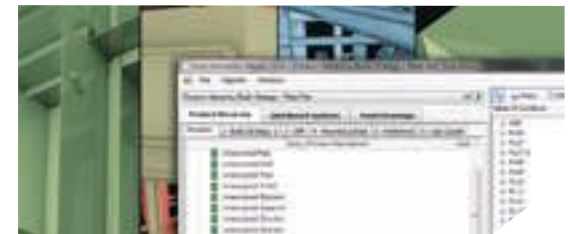

» Report Key Features

- Report by Product Hierarchy, System, or drawing
- Define custom report definitions
- Customize the presentation of report data
- Group report entries based on similar information
- Export reports to PDF, Excel, and Word

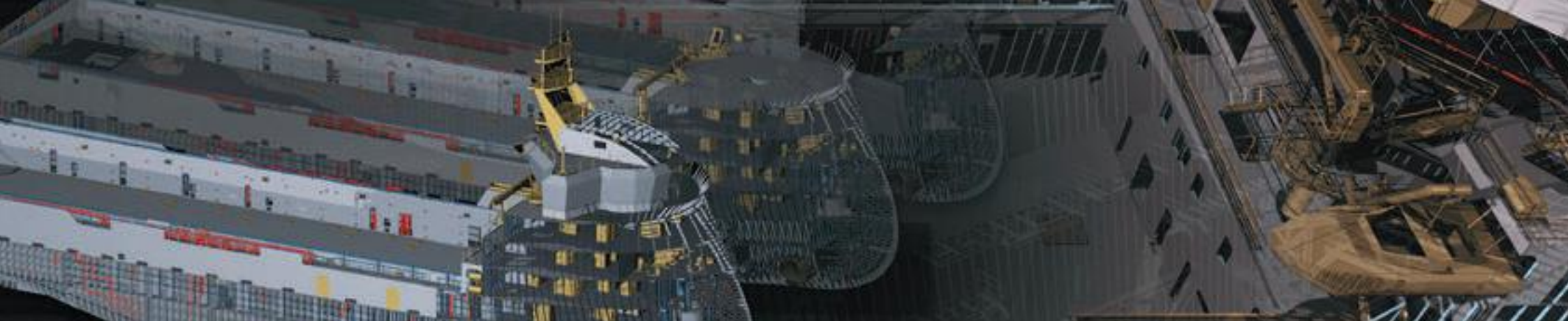

WorkShare Products: **WorkShare Project**

WorkShare Overview

WorkShare is a suite of tools & products to facilitate collaboration and the reuse of existing work. Capabilities include the ability to reuse targeted portions of existing 3D models, the ability to reuse entire blocks or systems along with the associated assembly information and production drawings, and the ability to implement distributed design of an entire project.

WorkShare Project Overview

WorkShare Project allows work on a single ShipConstructor project model at multiple locations. This is accomplished by using technology to merge distributed design back into a single 3D project model.

» Securely Manage Distributed Projects

WorkShare Project allows control over which parts of the project are distributed to each site, per block within the project and per discipline. Combining this level of control with permissions which can be used to restrict which users at the various sites can change stocks, standards, or make changes to the model or production output, creates a system which allows for secure, managed control over collaborative projects.

» Lower IT Overhead

The technology behind WorkShare Project is created to be managed by the users of ShipConstructor, not their IT departments. Additionally, the disconnected nature of WorkShare Project significantly reduces the overall IT infrastructure requirements (bandwidth, redundancy, reliability). This allows the solution to be implemented in both mature and emerging markets, and between enterprise organizations and small engineering firms.

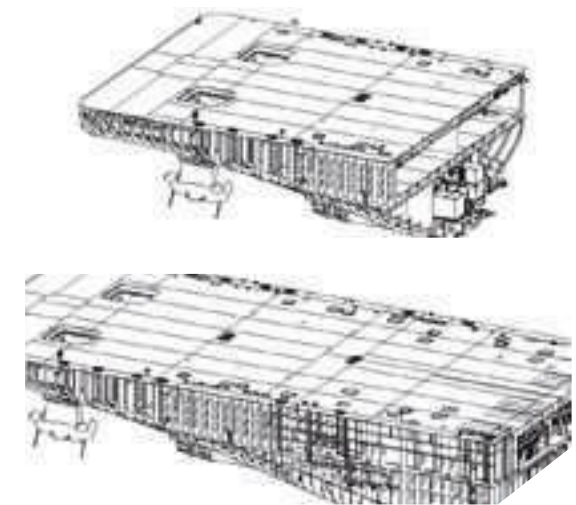

» WorkShare Project Key Features

- Split individual work units to sub-contractors or remote offices
- Individually control permissions for users across sites
- Refresh split projects with current project information
- Split design, and/or production activities independently
- Design / Model

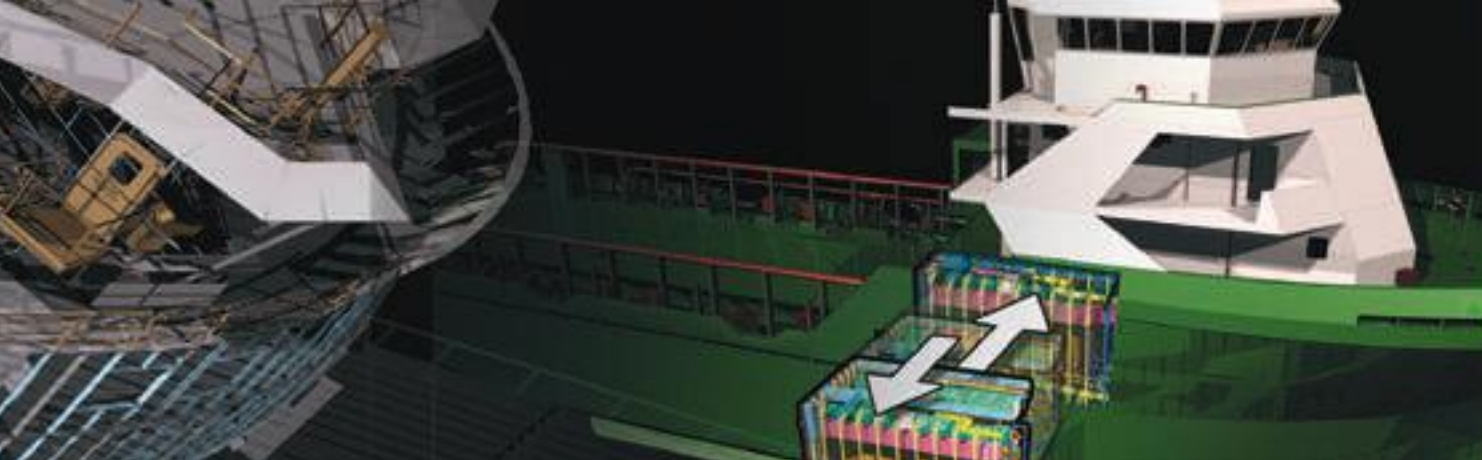

WorkShare Products: **WorkShare Design**

WorkShare Design Overview

WorkShare Design allows portions of a 3D project model, including assembly sequence, related production drawings and the underlying design intent to be captured and reused in another ShipConstructor project.

» Reduce Engineering Hours

Reusing existing work, and the underlying design intent, on new designs, sister ships, or within an ongoing project can significantly reduce the engineering man-hours required.

» Reduce Errors and Rework

Reuse not only lowers the effort required to complete a design, it also reduces errors and rework as the existing work has likely been built and checked in the past to a degree that a new design cannot have been.

» Standardize Production

Reusing standard blocks, systems or standards to a significant degree reduces the variation of designs seen on the shop floor and allows for a greater degree of optimization in production processes.

» Leverage Experience

By reusing existing designs that have been created or approved by more experienced engineers, junior designers or draftsmen can be more effective sooner.

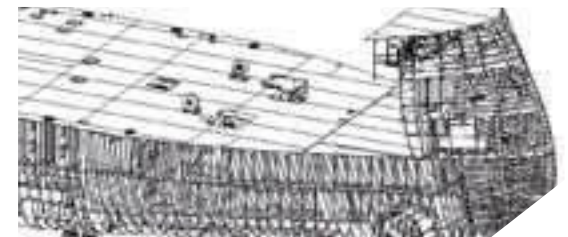
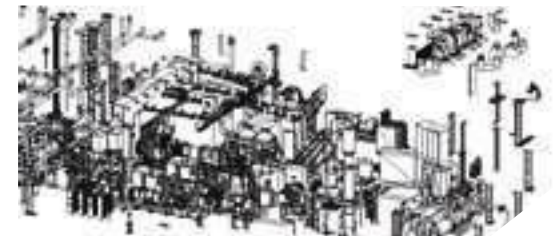

» WorkShare Design Key Features

- Copy part of an existing model between projects
- Snapshot the 3D model, design intent and production drawings for reuse
- Overwrite existing blocks or systems with modified information from sister ships



About SSI

» The Company

SSI develops Autodesk based solutions for the shipbuilding and offshore industry. SSI's flagship software is ShipConstructor®, an AutoCAD based CAD/CAM suite. These solutions take advantage of the native DWG platform and the global pools of experience provided by the world's most popular CAD platform. SSI combines this with industry specific standards, terminology and best practices. IT expertise is also applied to ensure the ability to share engineering data with other business processes and applications such as MRP, ERP or PLM tools. Shipbuilders, naval architects and marine engineers trust SSI solutions on a broad range of projects.

SSI solutions are flexible enough to handle the largest and most complex engineering challenges but can also be scaled down to be cost effective in any budget. The majority of US Naval warships are now built with the SSI solutions and prestigious names in global marine construction are increasingly choosing SSI to meet their needs.

» Our Vision

Since 1980, SSI chose a path which would continually demand that we look over the horizon and remain adaptable and agile in responding to constant and accelerating change in technology. Recognizing this reality, SSI has since created the most innovative, adaptable, scalable and accessible software tools available to the industry. This has been accomplished in an extremely competitive environment and we feel the vision that has driven the company from its inception has provided the foundation for our most fundamental competitive advantages. We are committed to the belief that the pace of change in technology demands an agile solution that can readily integrate with the best available technology. Our commitment to integrating with proven, commercially available technologies such as Microsoft SQL Server and products from Autodesk is part of this vision. SSI will remain committed to focusing on industry specific tools that are user friendly, easily adopted and can be implemented with minimal IT requirements.



The mission of SSI is to support and deliver increased productivity to the world's shipbuilding and offshore industries by bridging the gap between tradition and technology.

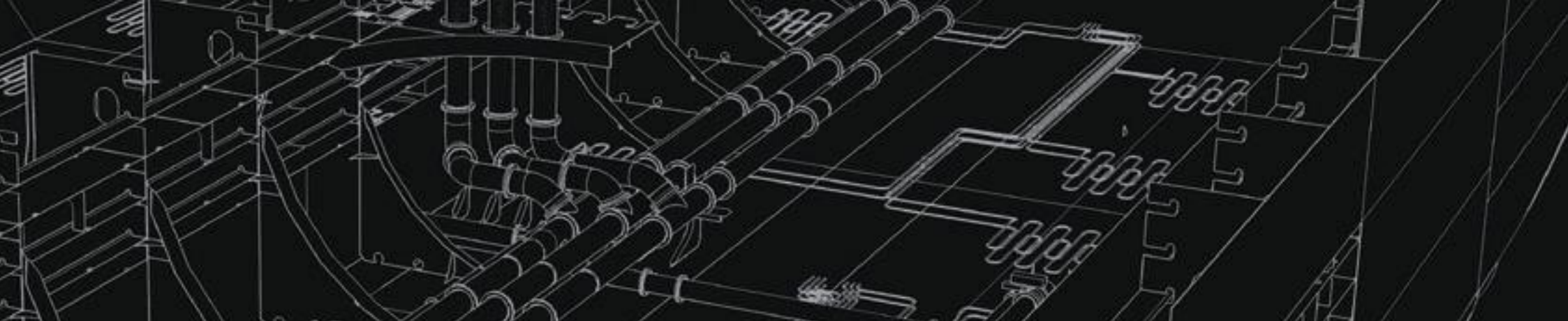

The result of these core values is innovative and adaptable software that facilitates the highest degree of workforce proficiency and allows clients to reach a superior level of capability faster than any other solution. Additionally, the broad appeal of our products has demanded a solution that will cost effectively scale from use on relatively simple projects such as barges, to managing the most complex navy, research and commercial shipbuilding and offshore projects in the world. We understand the direction of our industry. The pace at which the world is changing and that new technologies are becoming available is astounding even to those who are immersed in it. Due to the complexity, competition, and scale of shipbuilding and offshore projects, these technologies can have a significant impact on success or failure. To ensure success, our clients need to be capable of proactively adopting these new technologies and leveraging them to greater productivity. However, our clients' primary business is not IT services or software development. SSI will take ownership of this instead, ensuring that our clients can deliver on time and on budget.

Our vision for SSI is one of a trusted partner to the industry, responsible for introducing new technologies and capabilities to our clients with the benefits as well as the total cost of ownership fully analyzed. The goal is always to ensure that the available technologies can be optimally implemented and directly applied to our clients' specific business requirements.

SSI is committed to providing the vision our clients have come to rely on to chart a course through the constantly changing waters of technology. This vision provides our compass and our direction. We are excited about the future of SSI and thankful to the clients who have trusted their businesses to the products and services we that we offer. We will remain looking forward, embracing change and charting a course that our clients can trust.



www.SSI-corporate.com

EMPOWERED ENGINEERING



#304-3960 Quadra Street
Victoria, BC
Canada
V8X 4A3

Toll free: +1-888-210-7420
Tel: +1-250-479-3638
Fax: +1-250-479-0868

.....
sales@ssi-corporate.com
www.SSI-corporate.com

